

RDA HD 7X6 CE - Fixed Base Model

RDA THD 7X6 CE - Travelling Base Model

Heavy Duty 7M x 6M

Column and Boom

Red-D-Arc's RDA HD 7X6 CE (fixed base model) and RDA THD 7X6 CE (travelling base model) column and booms provide excellent welding results with maximum productivity through consistent and accurate placement of welding heads for automatic welding processes including inside, outside, longitudinal and circumferential welding applications and can also be used in conjunction with polishing and grinding heads. Structural steel with continuously welded roundways along with rack and pinion driven movement provide enhanced durability and extended overhaul intervals. Operated via push button pendant control providing 7 function boom control and 5 function travelling base control. Safety features include an integrated anti-fall device and UL /CE certified control boxes with IP65-rated enclosures. All Red-D-Arc column and booms have been tested and certified by UL to establish safe working loads - a first in the weld automation industry.

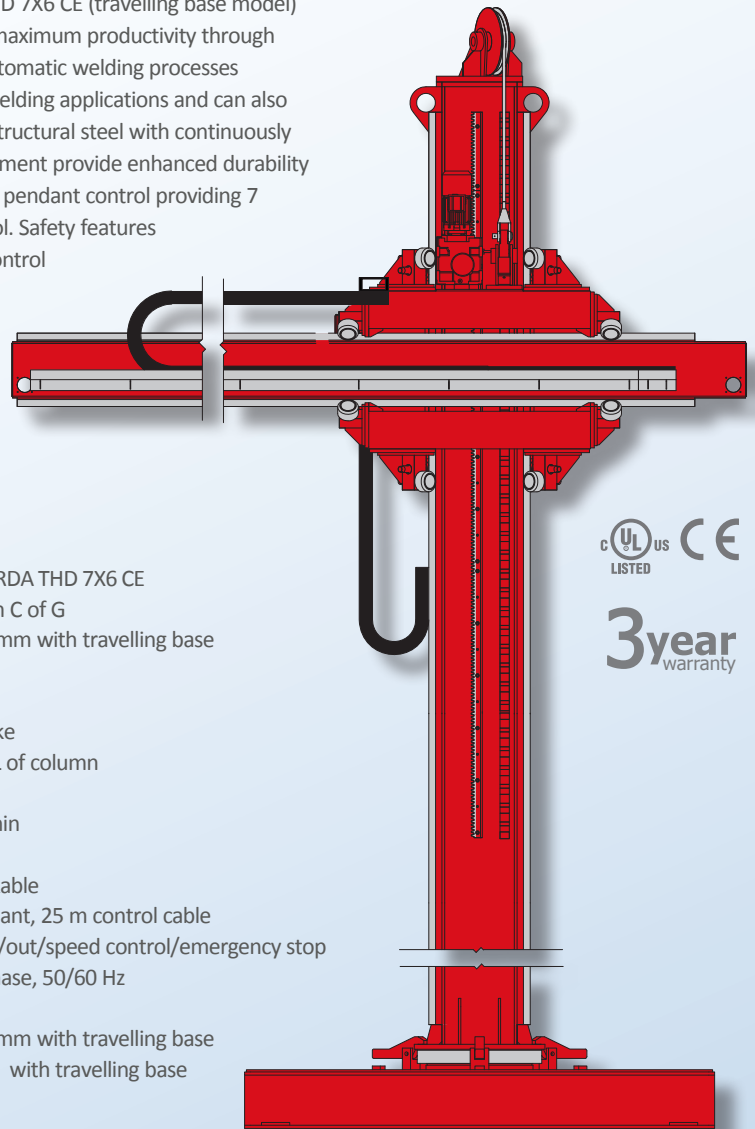

Specifications

Model	RDA HD 7X6 CE / RDA THD 7X6 CE
Maximum Load	454 kg @ 457 mm C of G
Max. Height Under Boom	7000 mm / 7025 mm with travelling base
Vertical Boom Travel	6000 mm
Vertical Boom Speed	2000 mm/min
Lift Motor	0.75 kW with brake
Max. Horizontal Extension	7081 mm from CL of column
Horizontal Boom Travel	6000 mm
Horizontal Boom Speed	100 - 2000 mm/min
Boom Motor	0.37 kW
Rotation	Manual 360°, lockable
Control	Push button pendant, 25 m control cable
Control Functions	Up/down/in/stop/out/speed control/emergency stop
Primary Input Power	380 to 480 V, 3 phase, 50/60 Hz
Input Current at Rated Load	6 A
Overall Height	8500 mm / 8525 mm with travelling base
Weight	7300 kg / 7800 kg with travelling base
Control Box Ingress Protection Rating	IP65
Control Box Electrical Certification	UL508
Loading Capacity Certification	UL2011

RDA THD 7X6 CE (Travelling Base Model)

Travelling Base Control	Uses column and boom push button pendant control
Control Functions	Forward/stop/reverse/speed control/emergency stop
Travel Speed	100 - 2000 mm/min
Rail Gauge	1800 CRS for A45 rail profile

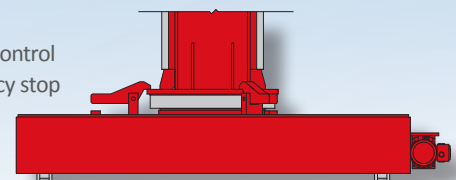

Red-D-Arc Welderentals rents and sells welding and weld-positioning equipment - around the world.

RDA HD 7X6 CE - Fixed Base Model
 RDA THD 7X6 CE - Travelling Base Model

Heavy Duty 7M x 6M
 Column and Boom

